

A high precision instrument for nanometric form analysis

The Talyrond 395 has been designed specifically for the measurement of precision components. The instrument's construction, external isolation and full CNC operation provide the platform required for the most demanding of environments.



Talyrond 395 for the measurement of precision components

Versatility	- automated arm attitude/orientation mechanism
Simplicity	- self calibration of the arm, column, spindle and gauge
Integrity	- high precision air spindle $\pm 0.01\mu\text{m}$
Precision	- gauge resolutions down to 1.2nm
Stability	- active vibration and environmental isolation system
Repeatability	- high accuracy position control of all axes

Talyrond 395

A high precision Roundness/Cylindricity measurement system for nanometric form analysis

Spindle Accuracy $\pm 0.01\mu\text{m}$

Ultra high precision roundness measurement of sub-micron components requires spindle accuracies down to nanometre level. The Talyrond 395 diamond turned air-bearing spindle is unsurpassed in radial and axial accuracy.

Gauge resolution to 1.2nm

With 1.2nm resolution the new Talymin 5 gauge is ideal for all high precision applications. The mechanical integrity of the crutch (fixed crutch optional) and pivot mechanism eliminates drift during the measurement cycle and assures stability of contact between the gauge and the component.

Dynamic vibration isolation

To achieve nanometric accuracy and repeatability, all potential errors must be eliminated. To isolate floorborne vibration from the measurement loop, Talyrond 395 includes dynamic antivibration mounts located between the support frame and base.

Automatic centring and leveling to sub micron target values

All components of the Talyrond 395 centre and level mechanism are machined to a high order of accuracy using materials that optimise resolution and repeatability. The centre and levelling process is so accurate it effectively simulates the relationship between the machine axis and component axis to bring the measurement closer to the manufacturing process. This feature is critical for inspection of coned seating faces.

Automatic axis and gain calibration

Two fast, accurate and unique calibration routines are available on the TR395. The first routine is used for automatic calibration of all the axis positions, the second will calibrate the instruments gauge head in seconds.

Environmental enclosure

Localised airflow, temperature fluctuations and contamination can all have an effect on precision measurement systems. The Talyrond 395 comes with a fully integrated enclosure that isolates the measuring platform from external environmental influences.

Stable cast iron base

The spindle, vertical column and horizontal arm are all anchored to a one-piece cast iron base. No other material can provide this level of stiffness and stability when measuring moving loads.

Accuracy built into every axis

Mechanical stability throughout the measuring loop is essential to reliable performance and measurement integrity. Every axis of the Talyrond 395 offers outstanding specification:

Vertical column straightness

$0.1\mu\text{m} + 0.0002\mu\text{m}/\text{mm}$

Horizontal arm straightness

$0.125\mu\text{m} + 0.000625\mu\text{m}/\text{mm}$

Traceable calibration

Any claim of roundness accuracy to nanometric levels must be supported with proof and traceability. Optional with every Talyrond 395 system is an ultra high precision glass hemisphere with roundness deviation less than or equal to 10nm and individual slope values of less than $2\text{nm}/7.2^\circ$.

This unique calibration artefact is used to monitor and prove that spindle performance is within specification.

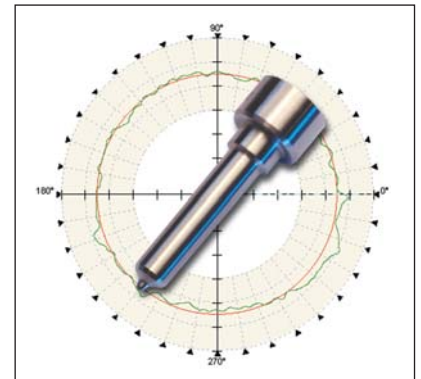

Fuel injectors



Calibration artefacts



Fluid dynamic bearings

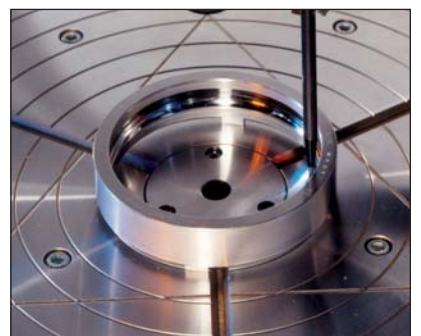

High precision bearings

Specifications are subject to change without notice. Note, not all features are included with all instruments. Please enquire for detailed specifications.

Serving a global market

Taylor Hobson is world renowned as a manufacturer of precision measuring instruments used for inspection in research and production facilities. Our equipment performs at nanometric levels of resolution and accuracy.

To complement our precision manufacturing capability we also offer a host of metrology support services to provide our customers with complete solutions to their measuring needs and total confidence in their results.

Contracted Services from Taylor Hobson

- Inspection services**
 measurement of your production parts by skilled technicians using industry leading instruments in accord with ISO standards
- Metrology training**
 practical, hands-on training courses for roundness and surface finish conducted by experienced metrologists
- Operator training**
 on-site instruction will lead to greater proficiency and higher productivity
- UKAS Calibration and Testing**
 certification for artifacts or instruments in our laboratory or at customer's site

For the above services, contact our Center of Excellence:

email: taylor-hobson.cofe@ametec.com
 or call: +44 116 276 3779

- Design engineering**
 special purpose, dedicated metrology systems for demanding applications
- Precision manufacturing**
 contract machining services for high precision applications and industries
- Preventative maintenance**
 protect your metrology investment with a Talycare service cover plan

For the above services, contact our Sales Department:

email: taylor-hobson.sales@ametec.com
 or call: +44 116 246 3034



0026



TAYLOR HOBSON
A8248 ISO9001

Taylor Hobson France

Rond Point de l'Epine Champs
 Batiment D, 78990 Elancourt, France
 Tel: +33 130 68 89 30 Fax: +33 130 68 89 39
taylor-hobson.france@ametec.com



Taylor Hobson Germany

Postfach 4827, Kreuzberger Ring 6
 65205 Wiesbaden, Germany
 Tel: +49 611 973040 Fax: +49 611 97304600
taylor-hobson.germany@ametec.com



Taylor Hobson Italy

Via De Barzi
 20087 Robecco sul Naviglio, Milan, Italy
 Tel: +39 02 946 93406 Fax: +39 02 946 93450
taylor-hobson.italy@ametec.com



Taylor Hobson Japan

Sankyo Meguro Building 4-5-37,
 Kamiosaki, Shinagawa-Ku, Tokyo 141-0021, Japan
 Tel: +81 33494 5110 Fax: +81 33494 5119
taylor-hobson.japan@ametec.com



Taylor Hobson Korea

Hungkuk Life Building, 5th Floor 6-7, Soonae Dong
 Pundang-Ku, Seongnam, Kyungki-Do, 463-020, Korea
 Tel: +82 31 713 1371 Fax: +82 31 713 1372
taylor-hobson.korea@ametec.com



Taylor Hobson China Beijing Office

Room 2305, CITIC Building #19
 Jianguomenwai Dajie, Beijing, 100004, China
 Tel: +00 86 10 8526 2111 Fax: +00 86 10 8526 2141
taylor-hobson.beijing@ametec.com



Taylor Hobson China Shanghai Office

Part A, 1st Floor, Waigaoqiao Free Trade Zone
 Shanghai, 200131, China
 Tel: +00 86 21 58685111-110 Fax: +00 86 21 58680969-110
taylor-hobson.shanghai@ametec.com



Taylor Hobson Singapore

AMETEK Singapore, 10 Ang Mo Kio Street 65
 No. 05-12 Techpoint, Singapore 569059
 Tel: +65 6484 2388 Ext 120
taylor-hobson.singapore@ametec.com



Taylor Hobson USA

1725 Western Drive
 West Chicago, Illinois 60185, USA
 Tel: +1 630 621 3099 Fax: +1 630 231 1739
taylor-hobson.usa@ametec.com



Taylor Hobson UK

(Global Headquarters)
 PO Box 36, 2 New Star Road
 Leicester, LE4 9JQ, England
 Tel: +44 116 276 3771 Fax: +44 116 246 0579
 email: taylor-hobson.uk@ametec.com

